

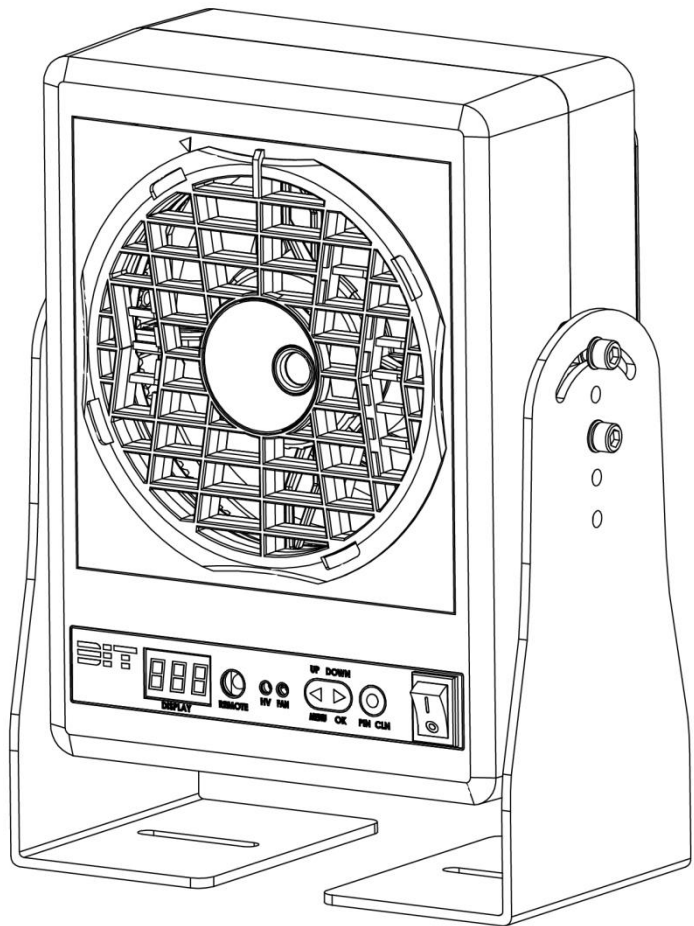

DONG IL TECHNOLOGY LTD.

Instruction Manual

ION BLOWER ASF-AD/PD Series



Read this instruction manual before using the product in order to achieve maximum performance.
Keep this instruction manual within your reach after reading so that it can be used at any time.

28, Namyang-ro 930beon-gil, Hwaseong-si, Gyeonggi-do, Korea
Tel 82.31.299.5453 Fax 82.31.357.2610

CONTENTS

- 1. Product Introduction03Page
 - 1.1 Features
 - 1.2 Specification
 - 1.3 Product lineup
 - 1.4 Dimensions
 - 1.5 Performance
 - 1.6 Package contents
 - 1.7 Parts' names and functions

- 2. Installation12Page
 - 2.1 Installation
 - 2.2 Wiring diagram
 - 2.3 Cautions

- 3. Cautions & Maintenance17Page
 - 3.1 Cautions for operation
 - 3.2 Cleaning & replacement of ion emitters
 - 3.3 Cleaning of fan

- 4. Settings21Page
 - 4.1 How to set values
 - 4.2 Explanation on Menu options

- APPENDIX23Page
 - 1. Trouble shooting
 - 2. Warranty

1.1 Features

Welcome to become a DIT customer!

ASF-AD/PD series are a ion blower neutralizing static electricity using Corona Discharge method.

ASF-AD/PD series,

- are easy to maintain with auto cleaning function for emitter pin.
- can be adjusted air volume up to 5-levels

1.2 Specification

Category	A TYPE	P TYPE
Ion generating method	Pulsed AC	High Frequency
Output frequency	10 ~ 50Hz (adjustable)	29kHz
Input voltage	AC100~240V(50/60Hz) or DC 24V±10%	
Input current	Max 0.8A	
Ion emitter pin	Tungsten or Titanium	
Ion balance	< ± 10V Typical	
Decay time	Better than 2.0 seconds at 600mm [Fan Speed Max(Level 5)]	
Air volume	Max 4.6m ³ /min per Fan	
Ozone generation	Under 0.005ppm	Under 0.05ppm
Display	7segment-Display, HV Alarm LED(G/R), Fan Alarm LED(G/R) ※ Green : Normal, Red : Abnormal	
Manual control	Fan Speed, Operating frequency, Ion-balance, Auto-cleaning, PLC Alarm Select, Address, Ionizer On/Off, Password	
Cleaning	Automatic / Manual (optional)	
Weight	Max 1.8kg	
Ambient temperature Relative humidity	0°C~50°C, 35~65%RH(No Condensation)	

1.3 Product lineup

※ CODE Structure

ASF - ① **D** ② ③

ASF : Single Fan Ionizer

① : A(Pulsed AC), P(High Frequency)

D : 120mm Fan Type

② : A(Auto pin cleaning), M(Manual)

③ : R(DC Type) _suffix

※ Product lineup

Model	Type	Cleaning	Input Power
ASF-ADA	Pulsed AC	Auto	AC/DC
ASF-ADM	Pulsed AC	Manual	AC/DC
ASF-ADAR	Pulsed AC	Auto	DC
ASF-ADMR	Pulsed AC	Manual	DC
ASF-PDA	High Frequency	Auto	AC/DC
ASF-PDM	High Frequency	Manual	AC/DC
ASF-PDAR	High Frequency	Auto	DC
ASF-PDMR	High Frequency	Manual	DC

1.4 Dimensions

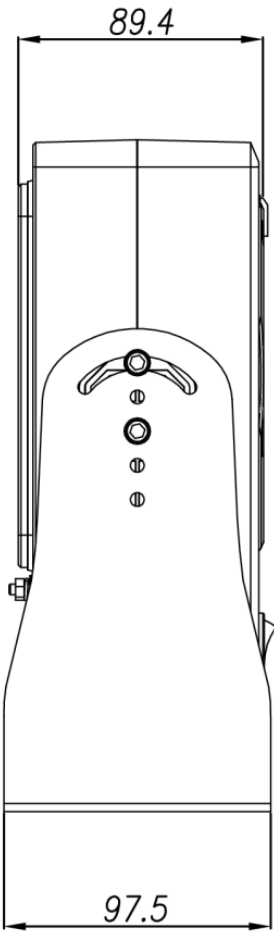

Side View

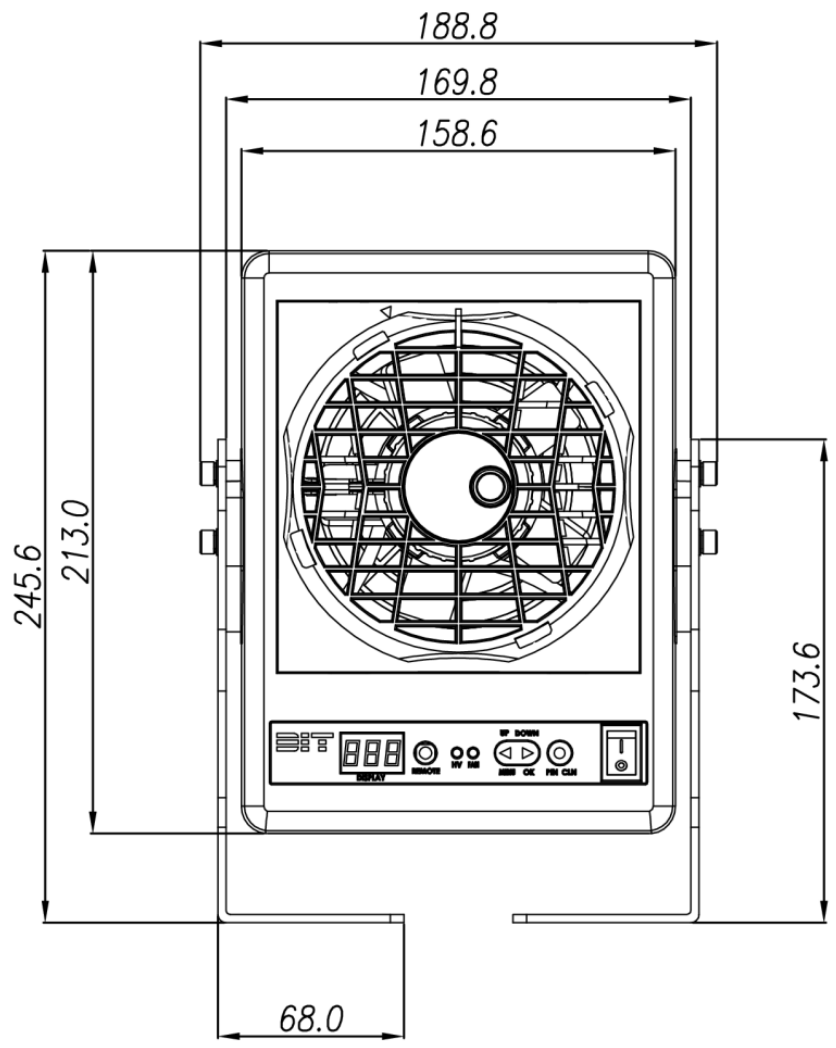

Front View

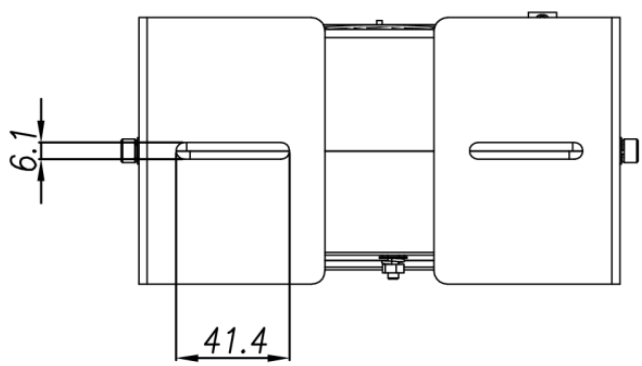

Bottom View

1.5 Performance

. Relation between Distance and Decay Time

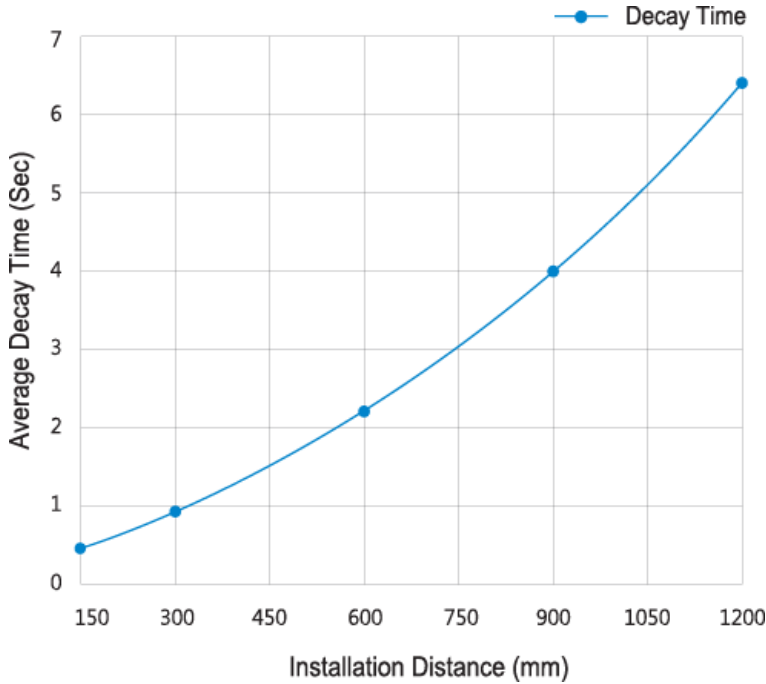

. Relation between Distance and Decay Time

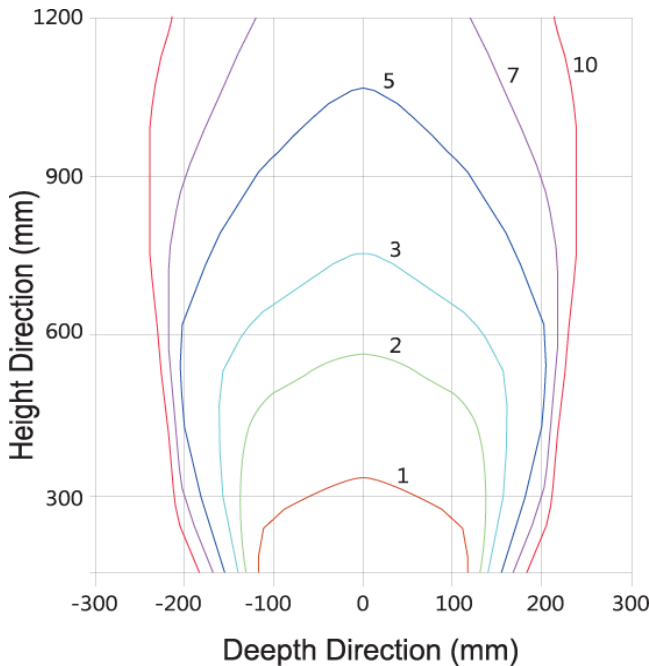

- . Fan Speed: L 5
- . Frequency : 30Hz
- . Measure Condition: 1kV →100V
- . Charged plate size : 150 x 150mm
- . Charged plate Capacitance : 20pF
- . Ambient conditions : 25°C, 45%RH

1.6 Package contents

Be sure to check the package contents before installation.

① Main body ② Standard brackets ③ AC power cable [1,800mm]

④ Ground Wire [1,500mm]

※ Options

⑤ Remote controller ⑥ DC power cable

⑦ RJ45 CABLE (8Pin) [PLC/ PLC/RS485 Communications]

① Main body

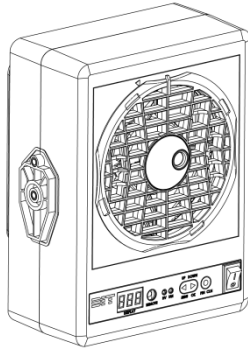

② Standard brackets

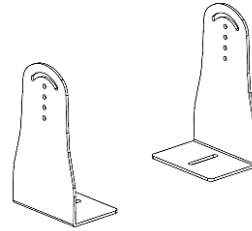

③ AC power cable



④ Ground Wire



※ ⑤ Remote controller ⑥ DC power cable



⑦ RJ45 CABLE (8Pin)
[PLC/RS485 communications]



※
O
P
T
I
O
N
S

1.7 Parts' names and functions

< Front-side >

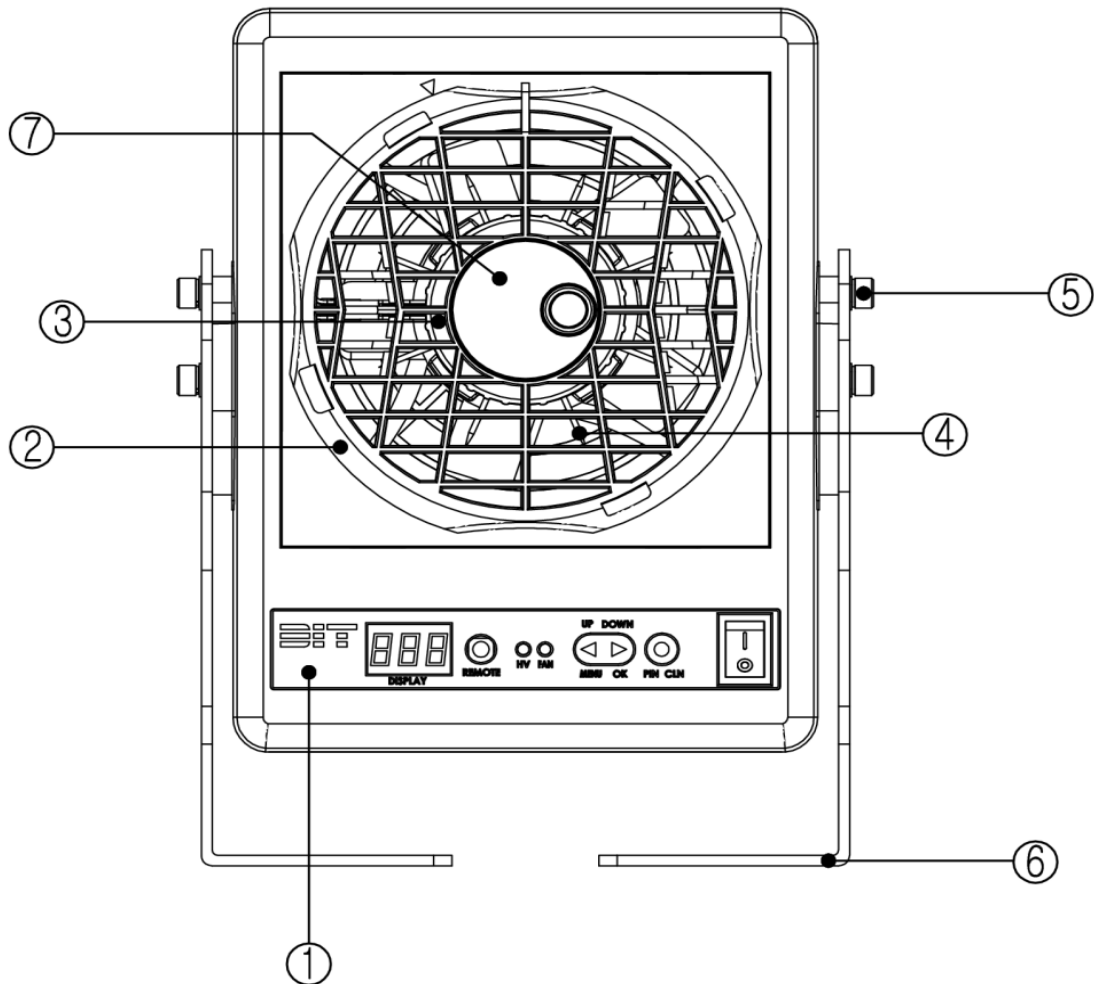

- ① **Control**
 - Display operation condition, menu and setting value
 - Control on/off AC input power
- ② **Air outlet and front cover**
- ③ **Emitter fixing cover**
- ④ **Ion emitter**
- ⑤ **Bracket fixing wrench bolt (M5)**
- ⑥ **Bracket**
- ⑦ **Rotating plate for cleaning**

1.7 Parts' names and functions

< Controller >

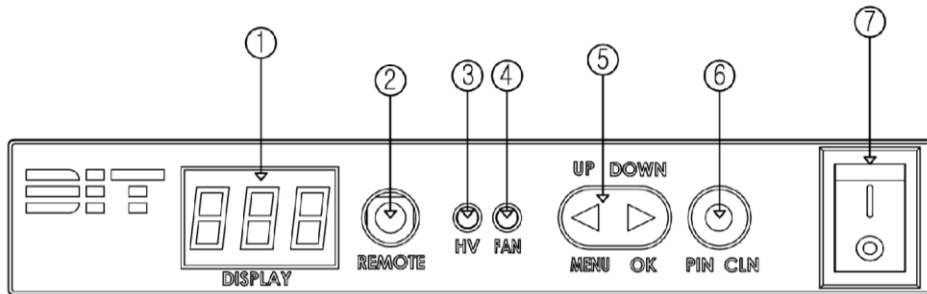

- ① **DISPLAY**
Display operation condition, menu and setting value
- ② **Remote Control receiver**
- ③ **Output power alarm (LED Green/Red)**
Shows the state of ion emissions
- ④ **Fan malfunction alarm (LED Green/Red)**
Shows whether fans are functioning properly or not
- ⑤ **Menu operation keys**
- ⑥ **Auto pin cleaning key [specific product only]**
- ⑦ **AC input power on/off key**

<Product condition and check point regarding LED>

Lamp	Red	Green	Check
HV	NG	Good	Ion Emission

Lamp	Red	Green	Check
Fan	NG	Good	Fan Status

1.7 Parts' names and functions

< Back-side >

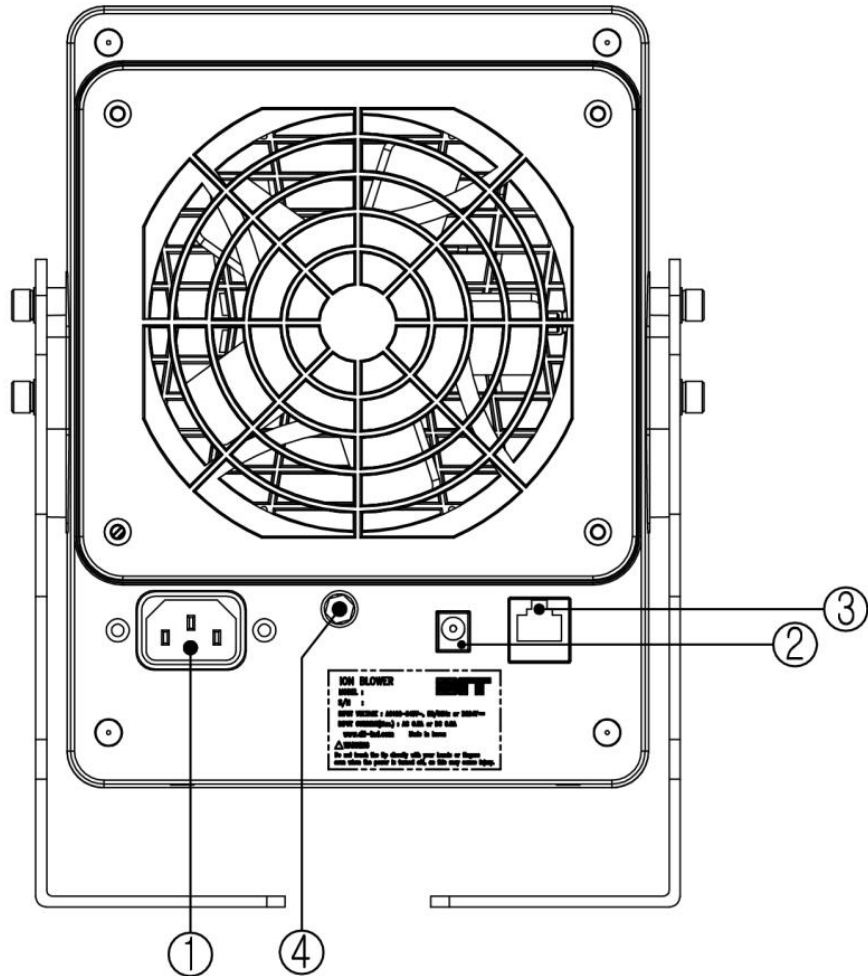

- ① **AC POWER Connector**
- DC type have no connector.
- ② **DC POWER Connector**
- Be sure to check a diagram(page 13.) before wiring.
- ③ **RJ 45 Connector**
- PLC cable, RS485 communication
- ④ **Ground cable connector**

1.7 Parts' names and functions

< Bracket >

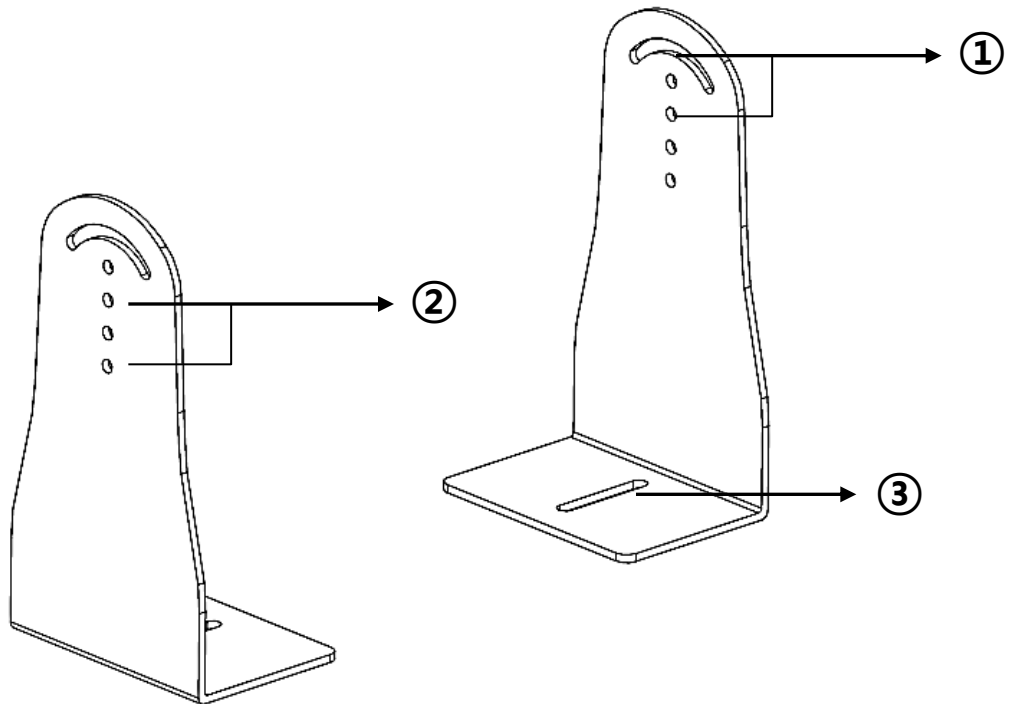
**① Tilt hole**

- Use this hole if you need to adjust angle.

② Height hole

- Use this hole if you need to adjust height.

③ Main body fixing hole

- Fix a main body to installation place before operation.

2.1 Installation

- ① **Install this blower making sure no obstruction between the blower and the target object.**

Warning Separate air outlet part and target object, air inlet part and any object such as wall minimum 150mm to keep air flow smoothly.

Warning If you use more than 2 ionizers, keep a distance minimum 200mm from each ionizer. If not, ionizers may no longer work ordinarily.

- ② **Fix strongly a main body to installation place with provided brackets.**
- ③ **AC Power cable must be plugged into a socket with proper ground connection.**

Warning In case of no ground connection in a socket, connect ground cable using a provided DC24V power cable. No grounding may cause a malfunction.

- ④ **In case of using DC power supply, be sure to connect the ground wire in DC24V cable included in the package referring the wiring diagram 2.2.**

Warning The product must be connected to prevent electric shock and guarantee best performance.

- ⑤ **When power is supplied, LED is lit on in red and, is turn into green within a second. From then, ions are released to neutralizing static electricity.**
- ⑥ **Control suitably fan speed to a install place.**

Warning Fan speed is quicken slowly because a motor spend a lot of electric power. If you need to control fan speed, set a value on menu after fan speed is fast enough.

- ⑦ **[ASF-AD] Check ion balance within $\pm 30V$, if not, adjust ion balance referring 4.1~4.2.**

- ⑧ **[ASF-PD] No need to adjust ion balance because of auto-balancing circuit.**

Warning When ion balance is within $\pm 30V$, check emitter pins.

2.2 Wiring diagram

< 24V DC Power Input Cable >

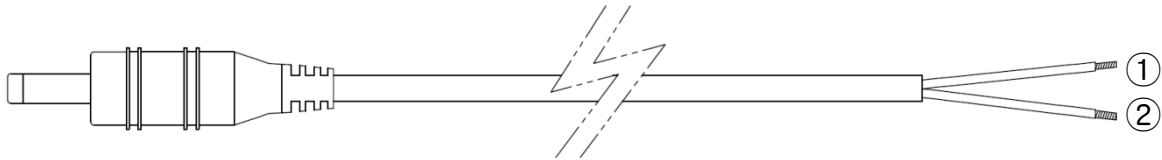

PIN No.	Color	Connection & Usage
①	Black	Power Ground (DC Power Ground)
②	White	+24V DC Power Supply

▪24V DC power input cable wiring

- 1) Connect Black wire to power ground.
- 2) Connect Red wire to DC + 24V.

< RJ45 Cable Wiring >

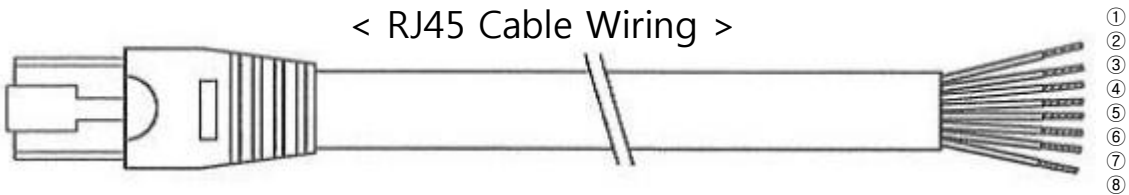

PIN No.	Color	Connection & Usage	
①	Black	Communication TX(+) Signal	RS485 Communication
②	Brown	PLC Circuit HVPS Alarm Signal	PLC
③	Red	-	
④	Orange	PLC Circuit Clean Signal	
⑤	Yellow	PLC Circuit On/Off Signal	
⑥	Green	Power Ground (DC Power Ground)	
⑦	Blue	PLC Circuit Fan Alarm Signal	RS485 Communication
⑧	Violet	Communication TX(-) Signal	

2.2 Wiring diagram

<ASF-AD/PD Series PLC(NPN Type) Circuit Diagram>

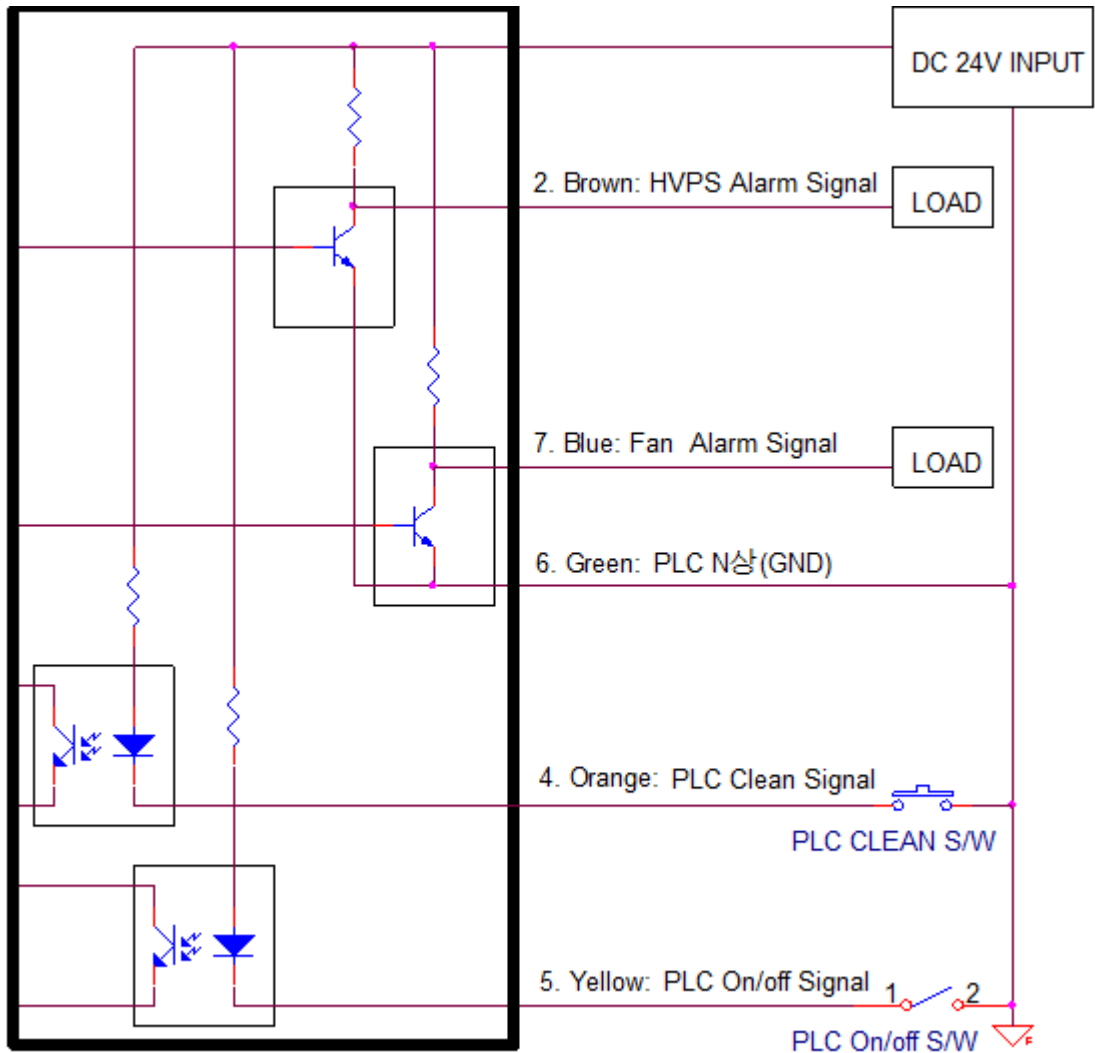

▪ Connection when using PLC

- ① Connect the green cable to a power and field ground.
- ② Connect the orange(emitter cleaning) and yellow(PLC on/off) cables to PLC 0V, which makes PLC work. If you open it, PLC doesn't work (Please refer to the ASF-AD/PD Series PLC Circuit Diagram above.)
- ③ The brown(HVPS) and blue(Fan) cables are for an alarm signal.

Warning

Setting Load: Set the output current under 100mA.

2.2 Wiring diagram

<ASF-AD/PD Series PLC(NPN Type) I/O Table>

	Switch	Display	PLC Alarm 'nc'	PLC Alarm 'no'
Ion 'on'	Close	I_o	Low	High
	Open			
Ion 'off'	Close	P_o	High	Low
	Open	I_f		
HVPS error / Fan error		Er2 /Er4	High	Low
PLC cleaning signal input Switch Close		CLn	No PLC alarm output	

- You should use lock type switch when you use a PLC On/off function.
 - You can only control PLC when a switch is closed.
 - You should use non-lock type switch when you use a PCL Clean function.
 - Auto pin cleaning function is operated repeatedly while switch is closed.
 - While PLC Clean Switch on a diagram is closed, ions are not generated
- Warning** for safety reasons.
- R, C filter on input terminal is connected in parallel to prevent malfunction due to external environment or chattering noise. Keep close more than 0.5 seconds the switch when you use non-lock type switch.

2.3 Cautions

- ① Supply power only after you make sure that the power cable is wired correctly according to the wiring diagram in page 13.
- ② Ground installed equipment and ionizer. No grounding may cause malfunction. Bracket fixing screw parts on left & right side is not for grounding. Connect AC or DC power cable to ground.
- ③ Excessive or insufficient power supply may cause the product's disorder or malfunction.
- ④ Use only authentic parts supplied. Using improper parts may cause malfunction.
- ⑤ Be well informed of this instruction before installing or using the product.
- ⑥ Don't put extraneous materials like metal, wire, etc. near the product for safety.
- ⑦ Don't move, clean or touch the product during operation.
- ⑧ Remove water and oil from the place where the product is installed and avoid high temperature(50°C) and high humidity(RH 70%).
- ⑨ Don't use this product in the place influenced by strong magnetic field. It may cause the product's malfunction.
- ⑩ Don't use this product in the place where there is volatile material or a lot of dust. There is risk of explosion.
- ⑪ Wire all of cables when you supply DC 24V.

3.1 Cautions for operation

- ① Before connect the power cable, be sure to check the power supply specification and wiring diagram.
- ② Don't touch the product with a hand or other material during operation because high voltage is generated.
- ③ Don't use chemicals or detergent for cleaning the product.
- ④ Don't use this product for any other purpose except for neutralizing static electricity
- ⑤ Keep distance from the product during operation and don't breathe for a long time in front of air flow from the product
- ⑥ Firmly fix the main body not to fall.
- ⑦ Install the product beyond children's reach.
- ⑧ Don't install the product in the place exposed to flame, direct ray of the sun or a lot of dusts.
- ⑨ Be sure to check a ground on ionizer and equipment before operation and maintenance.
- ⑩ Use a soft cleaning product when you remove dust on a front cover.

3.2 Cleaning & replacement of ion emitters

Auto pin cleaning function operation method

① Using the button on a front side.

- When PIN CLN key on a controller be pressed auto pin cleaning function is started.

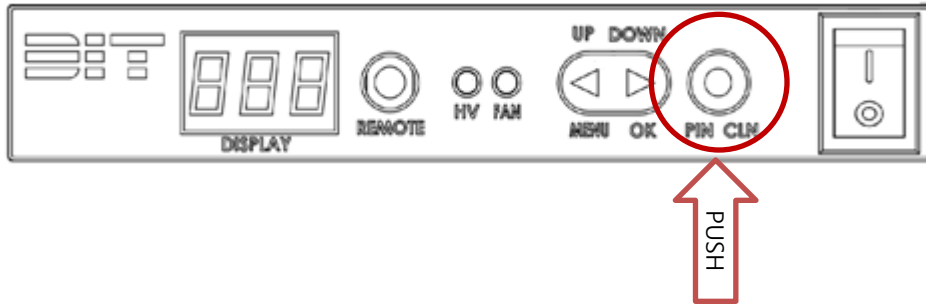

② Using the timer on menu.

- Set a value which cycle you want on menu 'tiP'.
- Refer to a detailed setting method on page 4.1.~4.2.

③ Using the PLC.

- Auto pin cleaning function is operated repeatedly while switch is closed.
- Refer to a diagram on page 3.2.

※ Please clean ion emitter pins regularly to guarantee the best performance of the product. (Cleaning period can be different according to the usage circumstances.)

3.2 Cleaning & replacement of ion emitters

Manual cleaning method of pin and cover

- ① Be sure to disconnect power before cleaning or replacement of ion emitters.
- ② Grab the fan cover(③), turn it counter clockwise
- ③ Hold the fan cover, pull it toward the body.
- ④ Remove a foreign substance with a compressed air or soft cleaning equipment.
- ⑤ Prepare a cotton swab with alcohol. Clean a emitter from inside to outside to prevent damage..
- ⑥ Be sure to check that a tip of emitter is damaged.

Warning When a tip of emitter is seriously damaged or broken, product performance is getting worse. Replace emitter pins after manual cleaning if required.

- ⑦ Assemble it in reverse order.

How to replace emitter pin

Do step ①~③ in manual cleaning method.

- ④ Turn a emitter pin cover(②) counter clockwise.to separate.
- ⑤ Replace a pin Ass'y(①).

Warning 'Be sure to assemble that the word 'Front' on cover is on a front side.

- ⑥ Assemble it in reverse order.

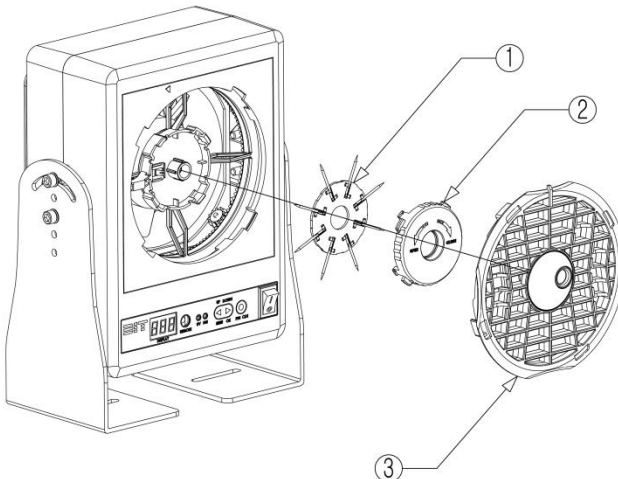

No.	Description
①	Emitter pin Ass'y
②	Emitter pin cover
③	Fan cover

※ Please clean ion emitter pins regularly to guarantee the best performance of the product. (Cleaning period can be different according to the usage circumstances.)

3.3 Cleaning of fan

How to clean Fan

- ① Be sure to disconnect power.
- ② Loosen 4 screws and separate a filter cover/case. (Figure 1)
- ③ Separate a fan softly to the back side of a product.
- ④ Remove a foreign substance with a compressed air or soft cleaning equipment. (Figure 2)
- ⑤ Assemble it in reverse order.

Warning A wire can be damaged with excessive assembly and disassembly,

Figure 1

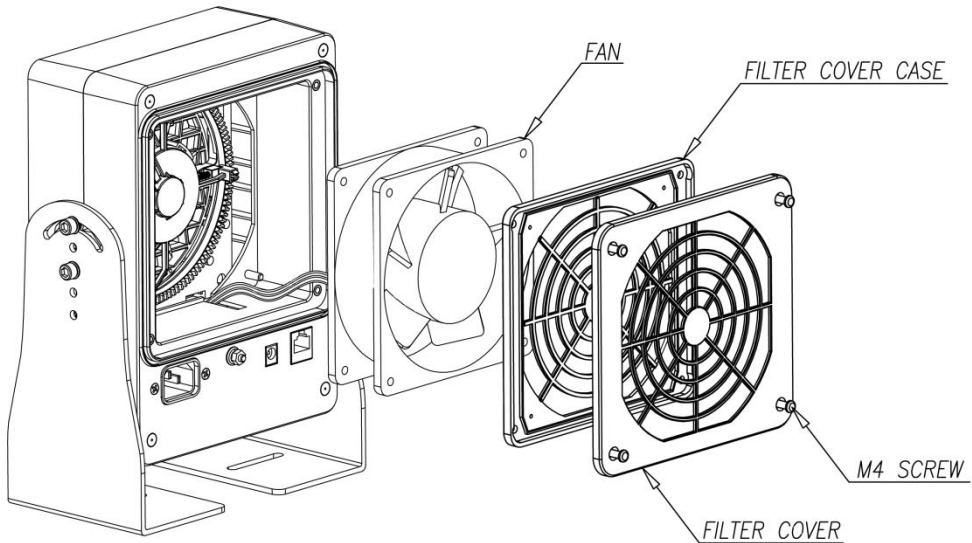
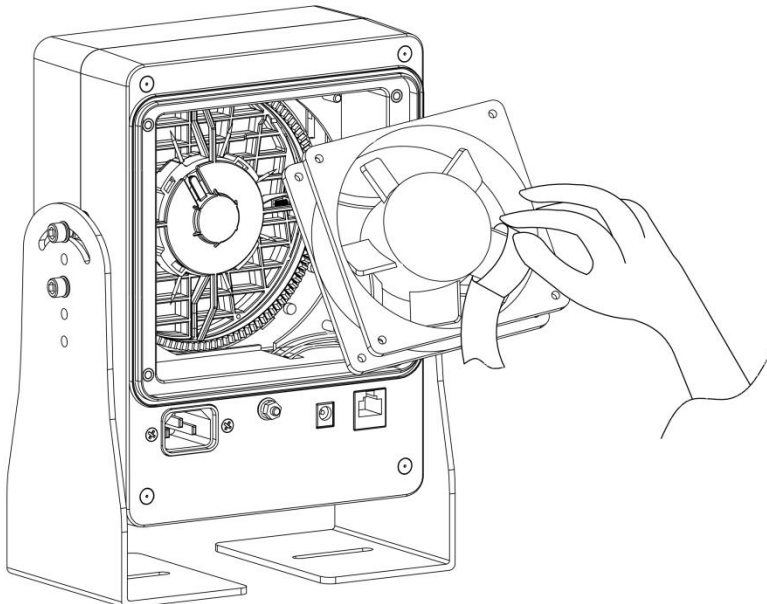

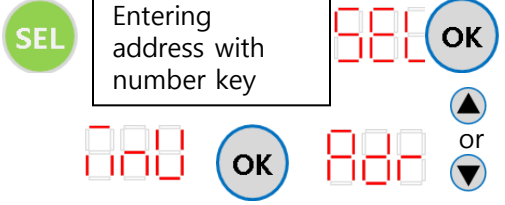

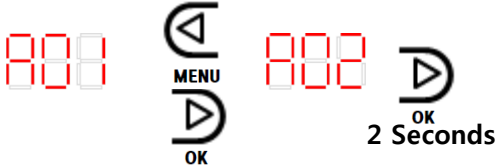

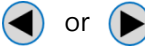



Figure 2



4. 1 How to set values

동작	When using key panel	When using remote controller ¹⁾
<p>Entering Menu mode and finding an option</p>	 <p>Press “Menu” key: “MnU” is displayed on the panel. Press OK to enter the main Menu. Use UP DOWN keys to find a specific menu option that you need.</p>	 <p>Entering right address display “SEL” on FND. Pressing “OK” display “MnU” on FND. Press OK one more time to enter the main Menu. Use “▲” or “▼” to find a specific menu option that you need.</p>
<p>Entering a specific menu option (Ex: Address setting)</p>	 <p>Hold “OK” for 2 seconds when the panel displays “Adr”. You can see the previous setting value on display..</p>	 <p>Hold “OK” for 2 seconds when the panel displays “Adr”. You can see the previous setting value on display.</p>
<p>Setting and saving a value</p>	 <p>Use “UP”, “DOWN” keys to change the value and press “OK” for 2 seconds to save the changed value.</p>	 <p>Use “▲” or “▼” to change the value and press “OK” to save the changed value.</p>
<p>Switching digits</p>	 <p>Press “OK” while holding “Menu” to be down digit. Press “Menu” while holding “OK” to be up digit.</p>	 <p>Press “◀” or “▶” to move to next digit. Check you have FND blinking. Use “▲” or “▼” to make changes.</p>
<p>Returning to initial Menu mode</p>	 <p>Press “MENU” for more than 2 seconds to return to initial Menu mode. Press “MENU” one more time to return to a standby mode.</p>	 <p>Press “ESC” to return to initial Menu mode. Press “ESC” one more time to return to a standby mode.</p>

1) Remote controller is optional.

4. 2 Explanation on Menu options

Menu	Description	Remark
Adr	Setting Address	Assigning "A01" – "A63" is allowed (up to 63 units). If there are duplicated addresses, controlling the system with a remote controller may result in false operation by controlling a wrong unit.
Ion ¹⁾	Ion On/Off	When ion output is "oFF", alarm LED changes to red and "I_F" is displayed on FND.
FrE ²⁾	Setting Frequency	Frequency output may range from 10.0 to 50.0 by 5.0 (increase/decrease)
Fan	Setting Fan Speed	Fan speed can be adjusted "oFF", "F-1"(slow) ~ "F-5"(fast). [5 -levels]
bAL ²⁾	Setting Ion Balance	Ion balance may range from 30.0 to 70.0.
tIP	Setting Emitter Pin Cleaning Period	If you set the value "YES" on menu, cleaning cycle is start. When cleaning cycle get to end, auto pin cleaning function is operate. Cleaning cycle can be set daily "t01 ~ t30".
PAS	Setting Password	When the password is on, you need to enter the old password to enter the main "Menu" for a new password setup. Password can be a three digit number, any number between 000 and 999.
PLC	Setting HVPS, Fan alarm output	nc: Normal operation - Output transistor is on. no: Normal operation - Output transistor is off.
Int:	Restoring initial factory settings	Factory setup is as follows. Adr : "A01" Ion : " on" FrE : "30.0" FAn : "F-1" bAL : "41.0" PAS : "oFF" PLC : " nc" tIP : " no"

- 1) Be sure to set the value "oFF" on Ion menu before use PLC on/off function.
- 2) This function is only available for AD type

Trouble shooting

Problem	Inspection
Both LED and fan don't work	<ul style="list-style-type: none"> . Check the power supply status. . Check the power cable connection in back side of the product . If the product doesn't work after checking all above, please contact your dealer.
H.V Alarm is red	If H.V alarm is still red 5 sec later after power connection, please contact your dealer.
Auto pin cleaning function doesn't work.	Please contact your dealer.
Fan doesn't work on power.	<ul style="list-style-type: none"> . Check the value 'oFF' on 'Ion' menu. . Check the value 'oFF' on 'Fan' menu.
Fan LED is red and the fan doesn't work	Please contact your dealer.
When you smell something metallic	It is natural smell generated when making high voltage.
When you smell something metallic	Immediately unplug the power cable and contact your dealer.
Auto pin cleaning function is continuous operating.	<ul style="list-style-type: none"> . Check RJ45 CABLE no. 5. . If the product doesn't work after checking all above, please contact your dealer.
the others	Please contact your dealer.

※ If you cannot solve the problem with the direction above or have other problems not described above, please call the manufacturer or leave a message on our website (www.dit-ind.com).

Quality assurance team : +82 31 299 5466

Warranty

We, Dong Il Technology Ltd. Manufactured this product under a strict quality control system and guarantee its quality for 1 year of period from the shipment date.

However, we don't take any responsibility for

- 1) Any damage if the product is used in a way different from that is explained in this manual or remade by users arbitrarily.
- 2) Any damage led by improper usage. We recommend the installation circumstances in this manual, but that is just a recommendation and users are responsible for understanding the product's specification and judgment of suitability of usage.
- 3) Direct or indirect damage led by the product malfunction.
- 4) The product specification can be changed without notice to improve safety and performance.